

MODEL S PADDLE DEPACKER

The Mavitec Paddle Depacker Model S is the leading solution for separating packaging from organic waste. With unmatched performance, it produces a superior clean organic output, setting the standard for biogas and composting installations.

- Maximum separation efficiency > 99,7%* clean organic output
- Fully adjustable to any type of food waste
- Robust and low maintenance design
- Variable screen sizes available
- Bolt free screen exchange
- Single tool paddle angle adjustment and exchange
- Quick opening doors for easy access
- Low installed power
- Stainless steel isolated splash shields for low noise operation

Capacity: up to 5m³ per hour

>99,7%
CLEAN
ORGANIC
OUTPUT

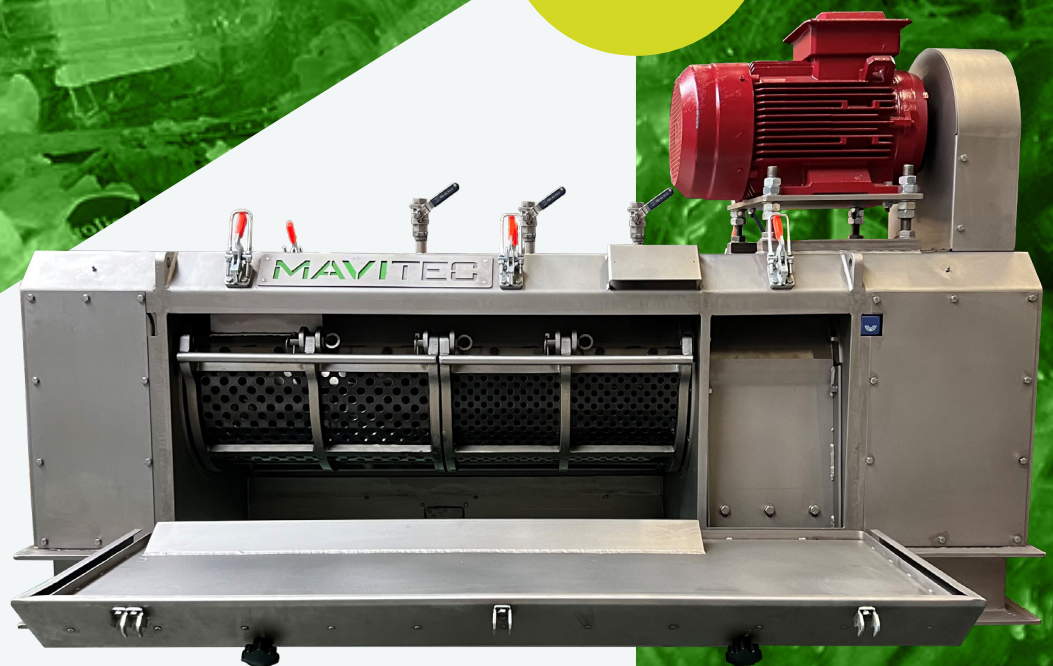

Designed for precise separation of packaging and organics

Designed to separate organic material from packaging and deliver the cleanest organic output in the market.

The machine efficiently depacks a wide variety of food waste streams and produces an exceptionally clean organic output, as well as the cleanest packaging fraction in the market. Thanks to its robust and intelligent design, the Paddle Depacker Model S can also run dry without compromising performance or reliability, ensuring maximum flexibility and operational continuity.

>99,7% clean organic output

How do we achieve the cleanest organic fraction?

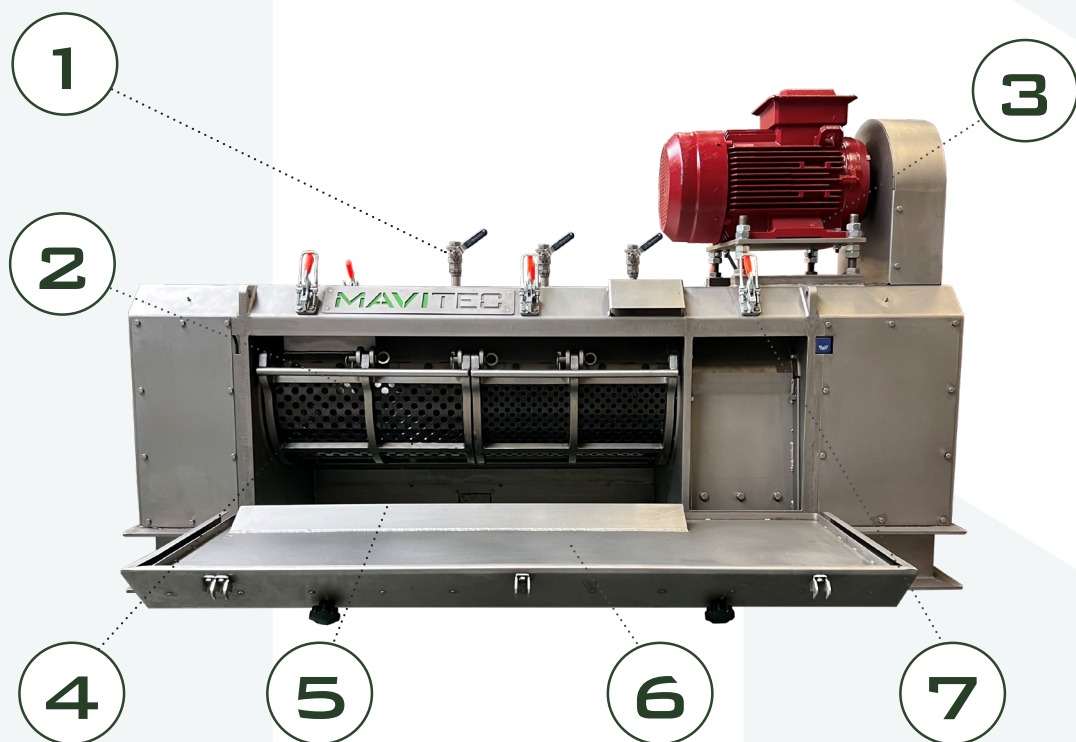

1. **Liquid dosing** optionally liquid can be added to ensures a homogeneous, pumpable organic slurry while enhancing the cleanliness of the packaging output
2. **Adjustable paddle angle** increases or decreases retention time for optimal separation efficiency and can be adjusted within 3 minutes using a single tool
3. **VFD-controlled variable shaft speed** ensures optimal separation performance while minimizing energy consumption
4. **Fast Interchangeable screens** options (6–50 mm) allow adaptation to material characteristics and end-product requirements with screens that can be replaced within one minute
5. **Adjustable paddle-to-screen clearance**, enabled by our unique spacer system, guarantees clean screens and consistently output quality
6. **Stainless steel isolated splash shields** for low noise operation and opens within one minute
7. **Quick opening doors** for easy access



“For smaller batches,
the Paddle Depacker Model S
turned out to be the
ideal and most efficient solution”

Marco Gonzalez - Plant Operator Spain

Proven performance in the field

With over 300 installations worldwide, the Paddle Depacker is proven in a wide range of applications and different feedstocks.

Customers benefit from stable performance, high output quality and reliable operation.



Built for Real-World Operation

The Paddle Depacker Model S is engineered to operate reliably under demanding, real-life conditions where input streams are seldom consistent. Whether handling different materials or changing volumes, the system continues to run steadily and efficiently at all times.

Designed with durability and performance in mind, it ensures a smooth process while safeguarding downstream equipment and minimizing operational disruptions.

Key benefits:

- Handles variable input streams with ease
- Maintains consistent output quality
- Reduces wear on downstream equipment
- Minimizes downtime and maintenance

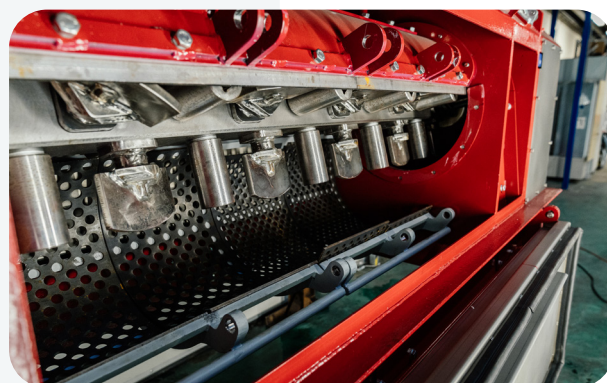

Test before you invest, proven on your material

To eliminate uncertainty, the Paddle Depacker Model S is available as a dedicated rental test unit. This allows operators to evaluate performance on-site and gain full confidence before committing to a full-scale installation.

The Paddle Depacker Model S can be installed as a standalone unit or seamlessly integrated into existing installations. The machine is fed via a hopper, bunker, or existing feeding system. Inside, a high-speed rotating shaft equipped with paddles breaks open the packaging and separates the material, forcing the organic fraction through perforated screens. Liquid can optionally be added to the process, while the Paddle Depacker Model S is also capable of running dry without compromising performance or reliability.

The organic fraction is collected at the bottom of the machine and can be pumped or conveyed to the client's storage solution or to our **Grit Cyclone**.

Clean packaging is discharged at the end of the machine and can be transported via a discharge conveyor to a client storage bay or press container. Optionally, the material can be directed to downstream equipment for further processing, such as a **Paddle Washer**.

Paddle Depacker Model S Skid Unit

The Paddle Depacker Model S Skid Unit is a unique opportunity to see the Paddle Depacker Model S running and test your own material.

The Skid Unit is a complete food waste depackaging unit, equipped with complete Paddle Depacker Model S system, handling up to 5 m³ material per hour. Including 2,5 m³ single screw, feeding hopper, Paddle Depacker Model S and discharge options for organic material (wet and dry) and plastics.

The unit is operated easily by a digital control panel with touch screen and is up and running in less than 1 hour; only power and/or liquid is needed.

Want to see more? See it in action

Discover detailed test results, customer applications and technical information on our website.

You can also scan the QR code to watch real-life test and installation videos on the Mavitec YouTube channel, showing the Paddle Depacker Model S operating on real material under real plant conditions.

From on-site testing to full-scale operation, proven performance you can see for yourself.

For site visits contact sales at info@mavitec.com

Scan the QR code to watch the videos, request a commercial offer or ask for more information.



Section:
Depacking

PADDLE DEPACKER MODEL S



Input: various types of food waste

Model	Capacity m ³ /hr	Power kW	Weight kg	Length (A) mm	Width (B) mm	Height (C) mm
S	5	15	1200	2200	850	1320

Features

- Maximum separation efficiency > 99,7%* clean organic output
- Fully adjustable to any type of food waste
- Robust and low maintenance design
- Variable screen sizes available
- Bolt free screen exchange
- Single tool paddle angle adjustment and exchange
- Quick opening doors for easy access
- Low installed power
- Stainless steel isolated splash shields for low noise operation
- Capacity: up to 5m³ per hour

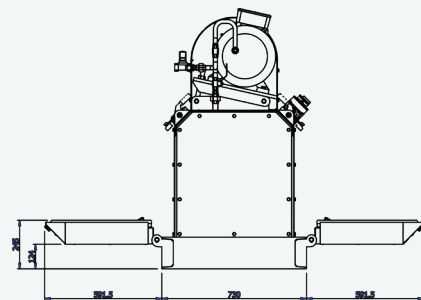
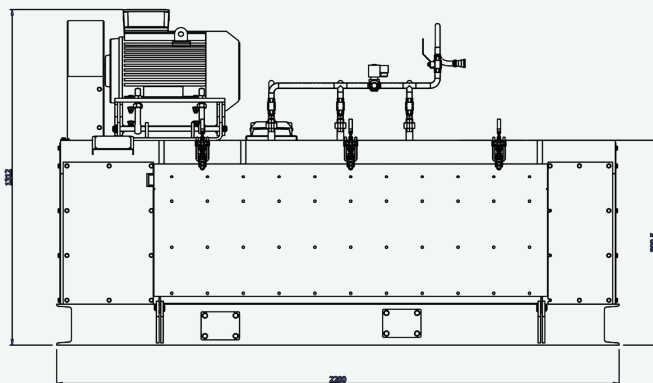
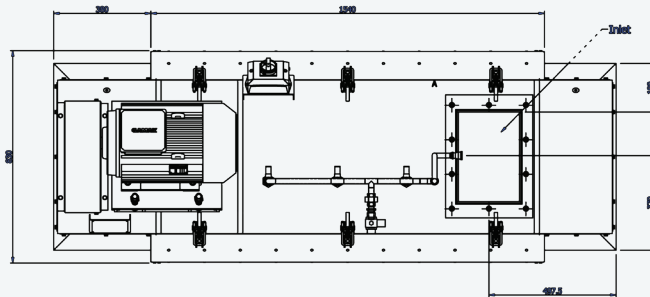

Due to ongoing product improvements, data shown here is subject to change without notice.
Contact Mavitec BV for latest specifications.



MAVITEC
GREEN ENERGY



Mavitec Green Energy

Galileistraat 32
1704 SE Heerhugowaard
The Netherlands
+31 (0)72 574 59 88
info@mavitec.com
mavitec.com

Part of the Mavitec Group