

Martinater



The Martinater 500 and 700 is your ultimate hammer mill solution designed for the efficient grinding of co-products. Versatile and adept, it tackles a diverse range of waste materials, from supermarket and restaurant/hotel discards to agricultural co-products and factory leftovers. This robust solution is tailored to reduce the size of various co-products with unparalleled efficiency and effectiveness.

Features:

- Engineered for maximum durability and strength
- Streamlined and low-maintenance design
- Compact size
- Utilizes the efficient swing hammer principle
- Easily adjustable sizes with simple screen changes
- Dedicated collection section for tramp materials

Capacity:

- Up to 20m³/hr

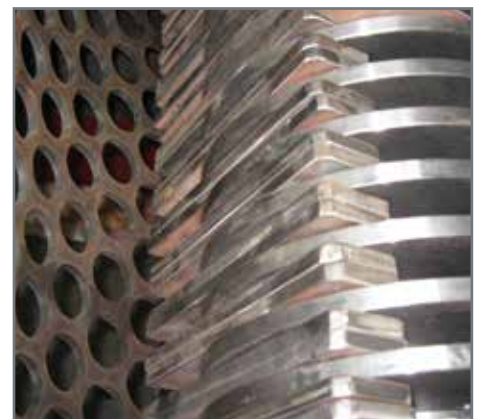

Hammer mills

Martinater

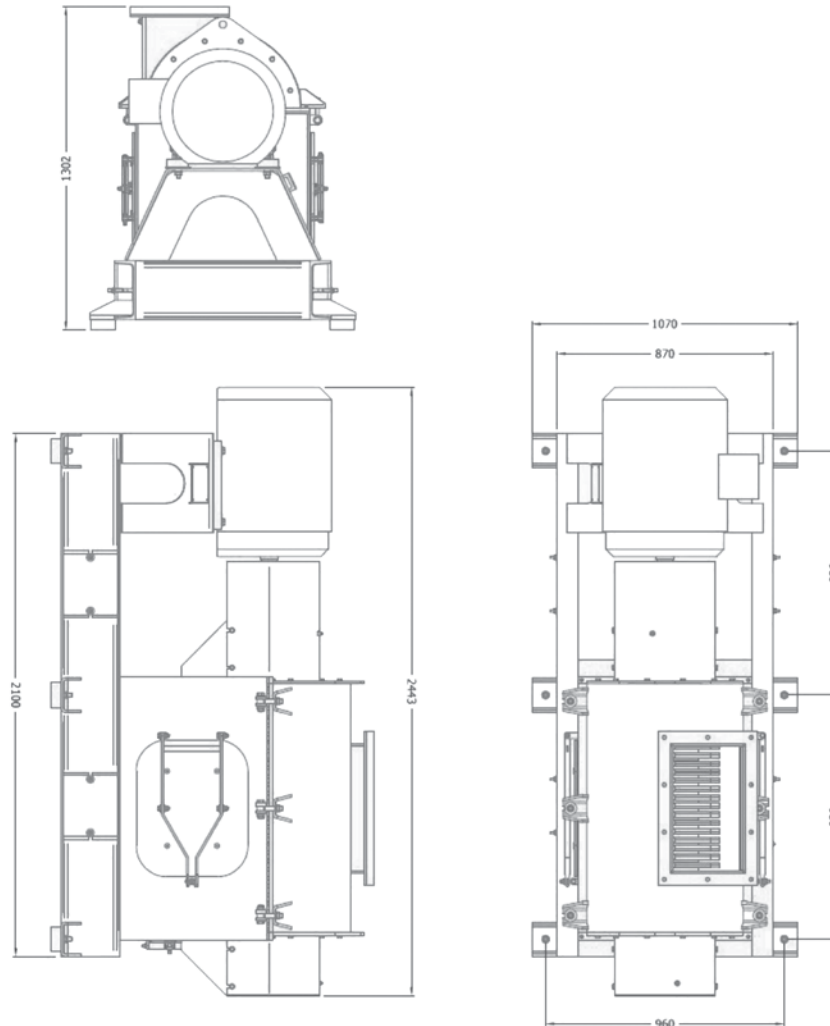

Martinater 700†

MA model	Capacity m ³ /hr	Power kW	Weight kg	Length (A) mm	Width (B) mm	Height (C) mm
500	10	22	1100	2050	900	1302
700	20	45	1600	2443	960	1302

Please note that the data presented here is subject to change without notice due to ongoing product improvements. For the most up-to-date specifications, we recommend contacting Mavitec B.V. directly.



Maximize the value of your by-products!

Galileistraat 32 - 1704 SE Heerhugowaard - The Netherlands

Tel.: +31 (0)72 574 59 88 | E-mail: info@mavitec.com

www.mavitec.com