

# Shop Return Press

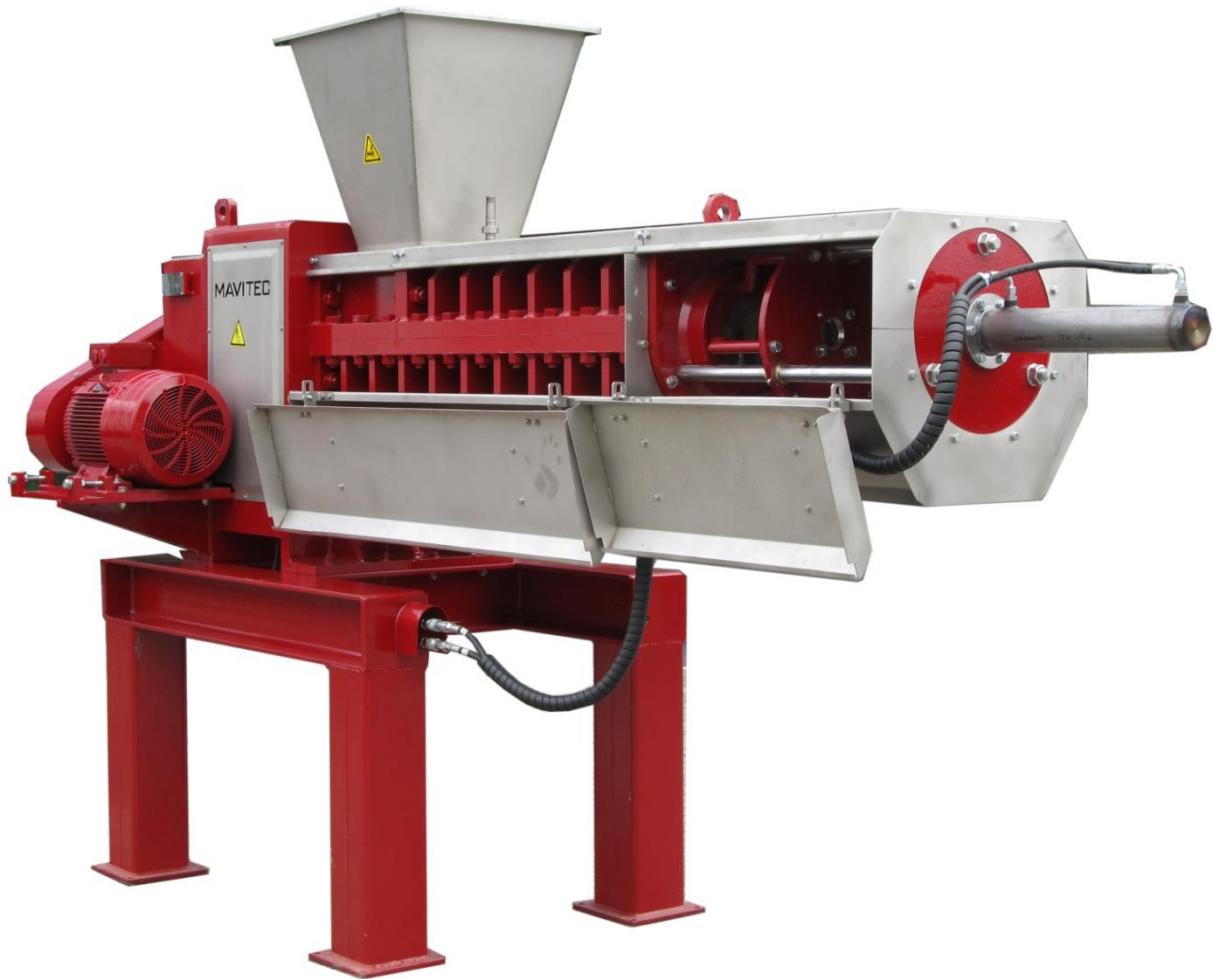

**Function:** Separation of organic material from various non-organic materials (Packaging)

**Features:**

- Stainless steel inlet hopper
- Stainless steel splash shields
- Stainless steel drip pan
- V-belt arrangement driven by a 22 kW engine
- Carbon steel main cage
- Replaceable barrel bar spacers
- Main shaft with continuous flight arrangement
- Including hydraulic choke



**Capacity:** 7,0 m<sup>3</sup>/hr up to 10,0 m<sup>3</sup>/hr depending on material composition

# Shop Return Press

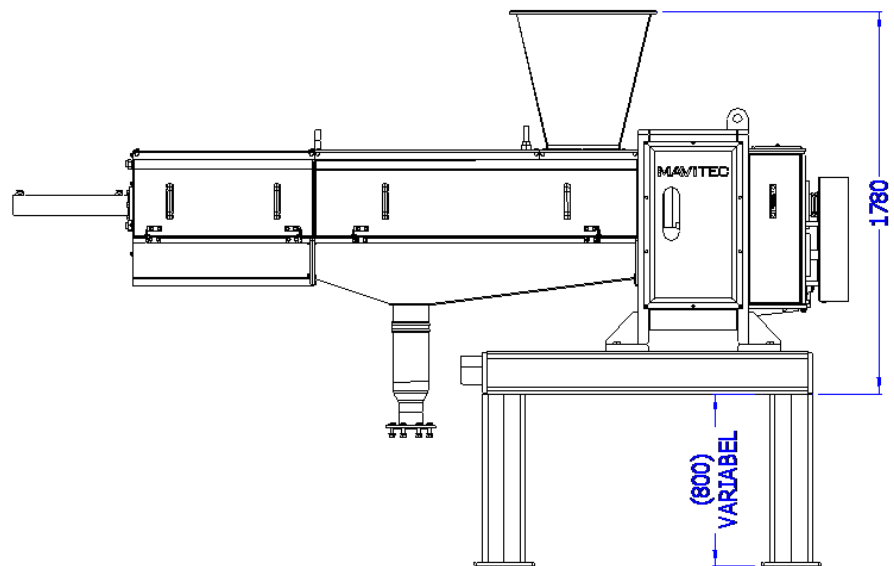
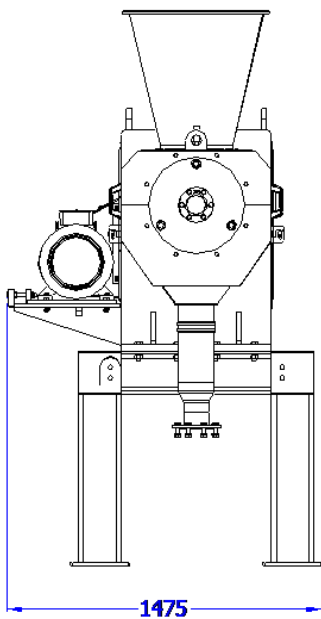
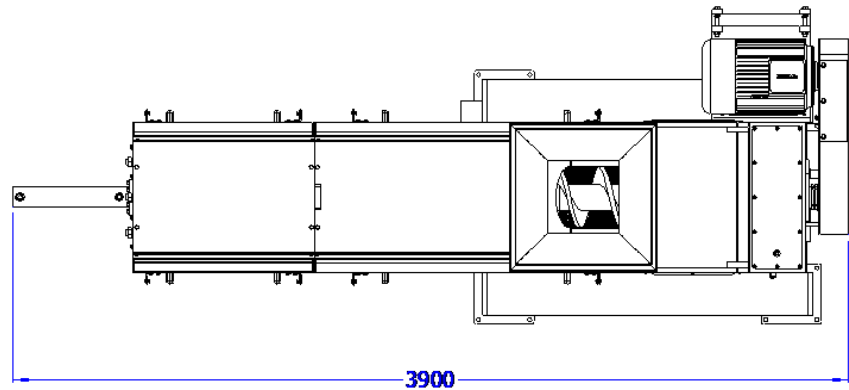

Due to ongoing product improvements, data shown here is subject to change without notice.  
Contact Mavitec B.V. for latest specifications.



Galileistraat 32, 1704 SE Heerhugowaard, The Netherlands  
Tel.: +31-72-574 59 88  
E-mail: [info@mavitec.com](mailto:info@mavitec.com) - [www.mavitecgreenenergy.com](http://www.mavitecgreenenergy.com)